



We Give You Gas

## **WARNING**

**Working with fuel is dangerous. If fuel is handled improperly it can lead to fires and death. It is imperative above anything else that all appropriate safety measures be used to control the fuel and any ignition sources, including static electricity, heat, sparks, and any other sources. Proper high-pressure fuel lines and connections must be used in accordance to the manufacturer's specifications and routed away from any potential sources of heat, ignition, and protected from mechanical damage. All wiring must be installed using proper strain relief, connections, insulation, and loom protection. If you are unsure about your work or safety, stop work immediately and consult with a qualified automotive technician and/or safety official.**

## **VaporWorx Single and Dual Channel Smart Relay Controller Installation Instructions.**

Thank you for your purchase of the VaporWorx Smart Relay Controller (SRC). These systems are designed to provide modern safety, convenience, and adjustability features for automotive relays. No pressure/Hobb's switches are needed. The SRC can be used in any application where a traditional relay may be used but requires a user-defined turn-on point between 0-5v:

- Second/Third fuel pumps
- Cooling fans and pumps
- Nitrous solenoids
- MAP, TPS, or other 0-5v sensor as the trigger source.

The SRC is to be used on 12v negative ground systems only. Each channel is rated for 40A.

VaporWorx was founded on Customer Satisfaction and Service. We strive to treat people and our products the way we would want others to treat us and the products we purchase. That is why our electronics products are tested thoroughly before they are packaged and shipped. VaporWorx stands behind our products for one full year after purchase with a well-stocked repair facility and quick turnaround times. VaporWorx does not want to be the reason you cannot enjoy your car. For off-road use only. The Terms of Warranty and Service are as follows:

### **Limited Warranty**

VaporWorx warrants its products to be free from defects in material and workmanship under normal use and if properly installed for a period of one year from date of purchase. If found to be defective as mentioned above, it will be replaced or repaired if returned along with proof of date of purchase. This shall constitute the sole remedy of the purchaser and the sole liability of VaporWorx. To the extent permitted by law, the foregoing is exclusive and in lieu of all other warranties or representations whether expressed or implied, including any implied warranty of merchantability or fitness. In no event shall VaporWorx be liable for special or consequential damages. This warranty is only valid on products purchased from VaporWorx or their Authorized Dealers. For off road use only.

### **Service**

In case of malfunction, your VaporWorx component will be repaired free of charges according to the terms of the warranty. When returning VaporWorx components for warranty service, Proof of Purchase must be supplied for warranty verification. After the warranty period has expired, repair service is charged based on a minimum and maximum charge rate. (Contact VaporWorx for current rates).

VaporWorx  
[carlc@vaporworx.com](mailto:carlc@vaporworx.com)  
(805)390-6423

**The following steps will help to ensure good system operation and long life. Careful attention to wire routing, protection, strain relief, connectors, crimps, etc. will lead to a longer lasting and more reliable installation. Be sure to use appropriate personal protective equipment and safe automotive lifting, support, and working methods. If there are any concerns stop work and consult with a professional automotive technician.**

- 1) Disconnect the vehicle battery.
- 2) Find a suitable flat surface to mount the VaporWorx Smart Relay Controller. Do not mount the SRC near sources of heat such as exhaust systems. The cooler the electronics are during operation, the longer their expected life will be. Screws are provided for mounting. The IRC can be exposed to water splash but care should be taken to not allow road debris, etc. to impact and damage the controller.

See Figure 1 for the following:

- 3) The SRC is provided in either single or dual channel arrangements. The large gauge wiring is the input and output for each channel. The same color wires are the same circuit. In other words, if one white wire is the input, the other white wire is the output. It does not matter which side is the input or output. Any signal (12v+ ground, 5v signal, etc.) may be used to pass through the relay at 40A maximum per channel.

Connect the heavy gauge input and output wiring as needed to the SRC. Use appropriate circuit protection (fuses, circuit breakers, etc.) on the input side near the source connection. Butt connectors or plug-type connectors may be used.

If using a plug connector, like the Delphi Weatherpack or GT series, confirm that the terminal system used will have sufficient power capacity for the intended load. Protect all wiring and connections using heat shrink tubing, wire loom, grommets, and good wire routing practices. 25A rated plug kits are available from VaporWorx.

- 4) Connect the 20ga red wire to an ignition 12v source. Use heat shrink tubing, wire loom, grommets, and good wire routing practices on all signals wiring.
- 5) Connect the 20ga black wire to a clean ground source.
- 6) Connect the 20ga light green wire to the sensor or source to be used to trigger the SRC relay(s) on/off. This can be any sensor or device with a 0-5v output range. Manifold Absolute Pressure and Throttle Position Sensors are common, but can be any linear voltage source. On/off sensors such as camshaft or crankshaft position sensors should not be used.
- 7) The SRC will turn on/off based on the input voltage on the light green wire. Hence, you will need to determine what voltage is needed to trigger the relay. For example, if using a MAP sensor for the light green wire trigger source, find out at what manifold pressure / output voltage is desired.
- 8) The R1 relay is pre-set to 2.11v on, R2 to 2.74v on. The relay will turn off at 0.36v below the turn-on setting. For dual relay controllers, the **R1 relay must be set to come on before R2.**
- 9) To change the turn-on point, attach a voltmeter to the measurement pin adjacent to the relay to be tuned. A jumper wire with alligator clips will make the attachment easier. Turn the vehicle ignition on and adjust the potentiometer to the desired relay turn-on voltage. See Photo 1 below.



Photo 1. Positive voltmeter lead is attached to the adjustment pin for the adjacent relay. Connect the voltmeter negative lead to ground.

- 10) The LED closest to the relay will illuminate when that relay is triggered on. To see if the relay and LED are operating, turn the ignition on and turn the potentiometer CCW until the relay triggers. After this check, reset the potentiometer as noted in Steps 7-9. A simple test light on the output/load side of the relay can also be used to determine if the relay is triggering while the car is running.

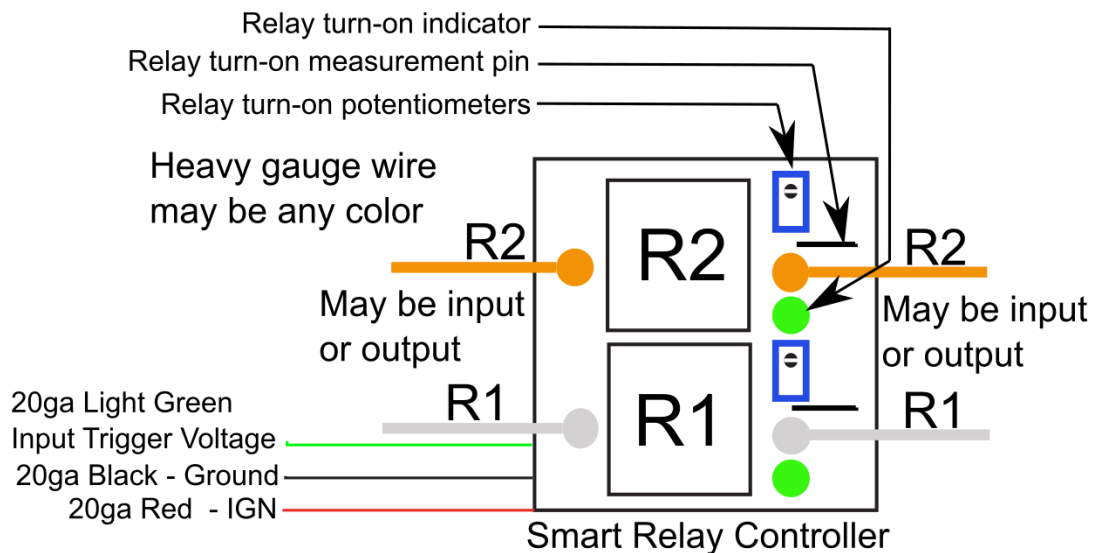

R1 must turn on before R2.

Turn potentiometer CW to increase the turn on point

# VAPORWORX Smart Relay Controller

Figure 1. SRC Dual Relay Controller diagram.  
Single controller similar.